

**Horizon**

# PC-450

Paper Cutter

## Powerful and Durable Paper Cutter



### Features

---

- 1. Accurate Cutting** - The backgauge enables you to adjust the cutting length accurately by 0.5mm / 0.019".
- 2. Cutting line** - The LED cutting line shows the actual cutting position. It allows the safe and smooth operation.
- 3. Safety** - The PC-450 is activated only when the two cutting buttons are simultaneously pressed. The machine does not operate when the front cover is opened. Also, if either of two cutting buttons is released during the cutting operation, the machine stops immediately. There is also the cover on the back of the table for the maximum safety.

With the cutting capacity of even A3 long-side width and maximum lift 70 mm / 2.75". Easy cutting operation by simply pressing the cutting buttons.

## Easy Operation

Clamp the stock by turning the pressure handle by hand, and press two cutting buttons.

## Cutting Length Adjustment

The backgauge can be adjusted by 0.5 mm / 0.019" by turning the handle at the front table. The backgauge can be locked when you repeat the same cutting job.

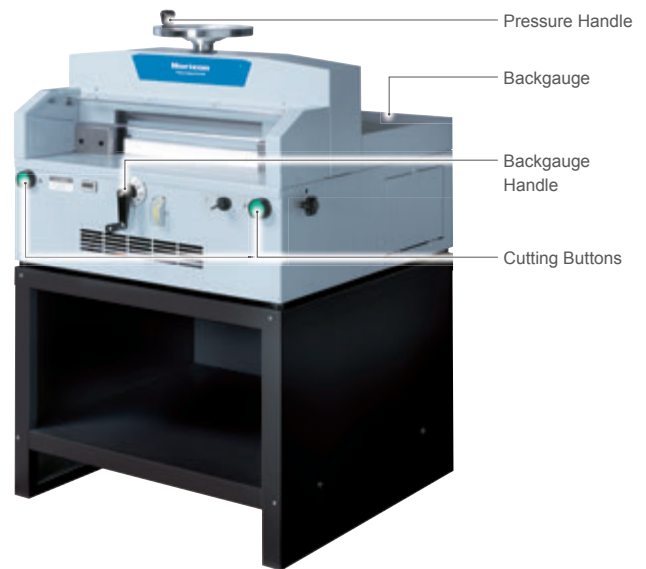

## Operator Safety

### Double Safety Circuit

If the error occurs, the machine detects the trouble part. Also, the relay with forcibly guided contacts are provided to secure the safety.

### Safety Mechanism

The machine does not operate when the front cover is opened. Also, if either of two cutting buttons is released during the cutting operation, the machine will be stopped immediately.

### Key Switch

The Power switch can be key-activated to limit user access.

## Clamp

The special cutouts are provided on both edges of clamp to prevent the book spine from crushing.

## Counter

Cut cycles are indicated on a digital counter. It helps to determine when the cutting knife should be replaced.

## Machine Dimension (Unit: mm or inch)

Height : 1,300 or 51.2"

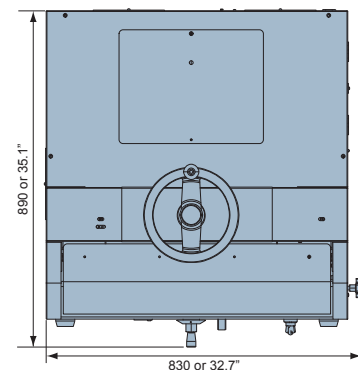

## PC-450 Specifications

Cutting Width		Max. 446 mm or 17.5"
Cutting Height		Max. 70 mm or 2.75"
Cutting Depth		Max. 450 mm or 17.7" Min. 20 mm or 0.79"
Clamp System and Pressure	Manual Max. About 10 kN or 1,000 kgf	
Cutting Speed	3.3 seconds per cycle (50 Hz) 2.8 seconds per cycle (60 Hz)	
Voltage/Frequency	Single Phase 115 V, 50 or 60 Hz Single Phase 230 V, 50 or 60 Hz	
Machine Dimensions	W830 x D890 x H1,300 mm or W32.7" x D35.1" x H51.2" (Including the parts projected such as handle) W800 x D810 x H1,190 mm or W31.5" x D31.9" x H46.9" (excluding the parts projected such as handle)	

\*The machine design and specifications are subject to change without any notice.

Distributed by

HORIZON INTERNATIONAL, INC.

510 Kuze Ooyabu-cho, Minami-ku, Kyoto, 601-8206, Japan Phone : +81-(0)75-934-6700, Fax : +81-(0)75-934-6708, www.horizon.co.jp